

DNAKE PRODUCT CATALOGUE

DNAKE (Xiamen) Intelligent Technology Co., Ltd.



01
ABOUT
DNAKE

www.dnake-global.com

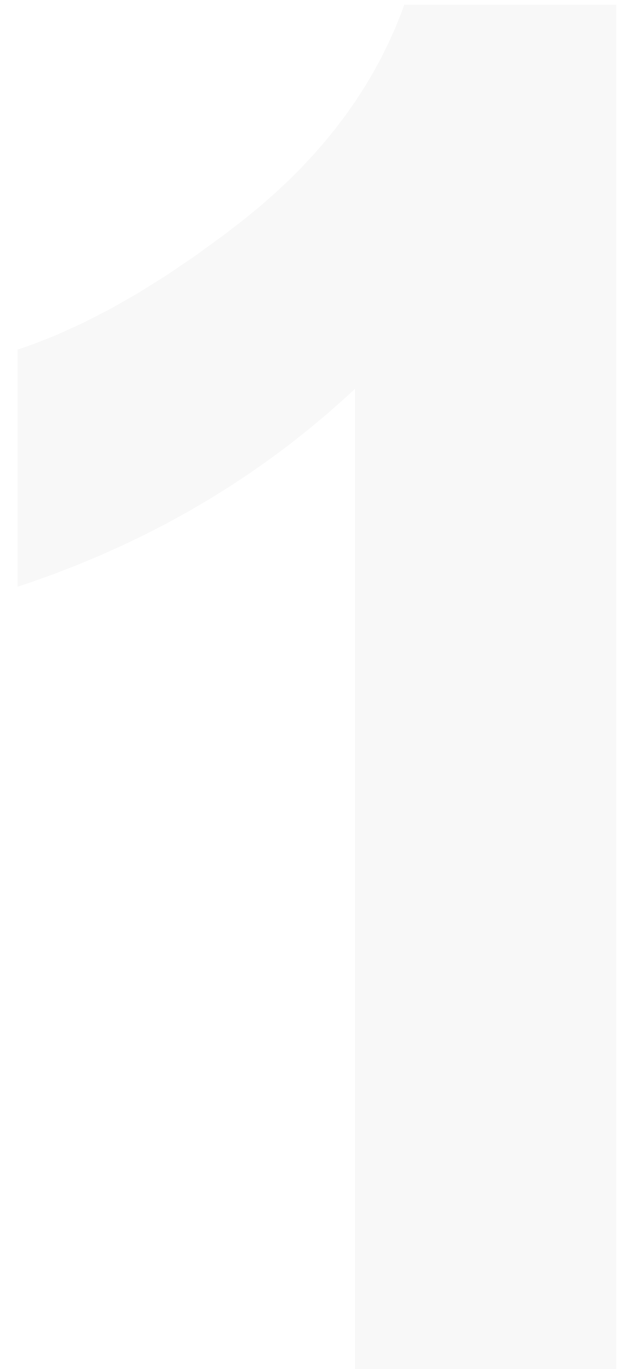

DNAKE MILESTONES

2005

DNAKE was founded.

2008

IP video door phone was launched.

2014

- Android-based intercom system was launched.
- DNAKE started establishing strategic cooperation with the top 100 real estate developers.

2013

SIP video intercom system was launched.

2017

DNAKE became China's top SIP video intercom provider.

2019

DNAKE ranked No.1 with preferred rate in Video Intercom industry.

2020

DNAKE (300884) was listed on the Shenzhen Stock Exchange ChiNext board.

2021

DNAKE invested more on the international market.

2023

Relocated to a new headquarter

2022

Ranked 22nd in global security

DNAKE COMPANY STRENGTH



LISTED COMPANY

Shenzhen Stock Exchange



Around 20 YEARS

IP Video Intercom Experience



10+ YEARS

International Team



50,000m²

DNAKE Technology Park



100%

Focus on Intercom Business



355

Patents & Software Copyrights



1300+

Employees



90+

Countries Covered

DNAKE POSITION IN THE MARKET

Ranked **22nd** in the 2022 Global Top Security 50



DNAKE POSITION IN THE MARKET



No. 1 Intercom Manufacturer in China



No. 1 Supplier of China's Top 500 Real Estate Companies



Top 10 in Public Security



Top 10 in Smart Home

R&D STRENGTH

Over **300** R&D Engineers

355 Patents and Copyrights



34

Invention
Patents



70

Utility Model
Patents



96

Appearance
Patents



155

Software
Copyrights

MANUFACTURING CAPABILITIES

2 Smart Production Bases, **19** Production Lines



Covering a Total Area of **50,000m²** technology park
With around **4.36M** Units Annual Production Capacity



STRICT QUALITY MANAGEMENT

Around **20** Years Industry-leading Quality



Our extensive certification is a testament to our capabilities and our dedication to meeting and exceeding industry standards.



WORLDWIDE CUSTOMERS

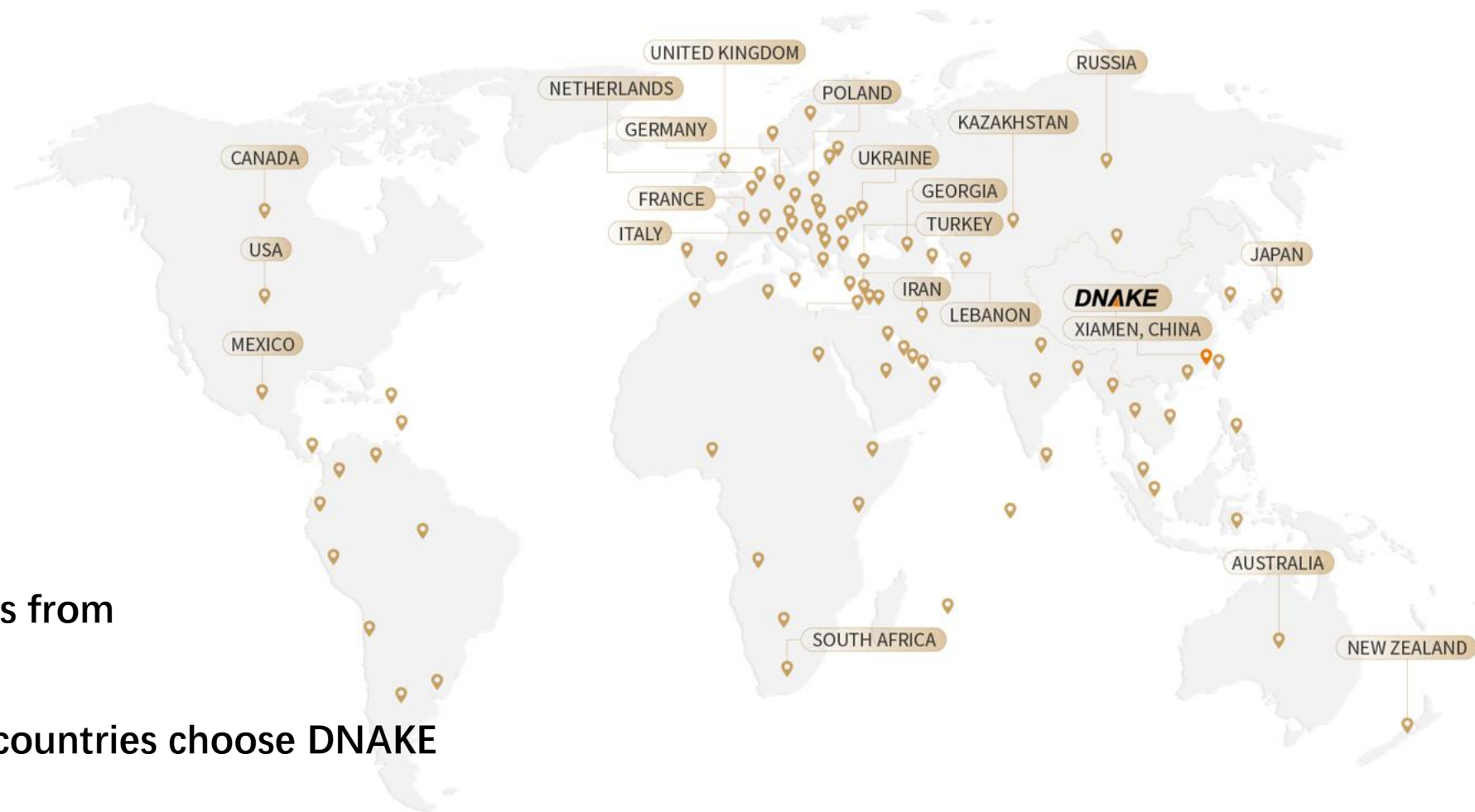

Customers from

90+ countries choose DNAKE

COMPREHENSIVE PRODUCT PORTFOLIO

Door Station	
Indoor Monitor & Master Station	
Wireless Doorbell	
2-wire Products	
Intercom Kits	
Software & Cloud Service	

BROAD COMPATIBILITY

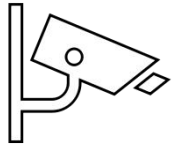

Security

ONVIF[®]

HIKVISION

alhua
TECHNOLOGY

UNV[®]
Uniview Technologies

Tiandy

TVT

Milesight



Home Automation

Control**4**[®]

tuya[®]

CRESTRON

SAVANT



IP Telephony

3CX[®]

Asterisk

Yeastar

Yealink

poly

GRANDSTREAM

CyberTwice
CLOUD RECORDING AND ARCHIVING

02

**DNAKE
SOLUTIONS**

www.dnake-global.com

Residential Solution - Villa

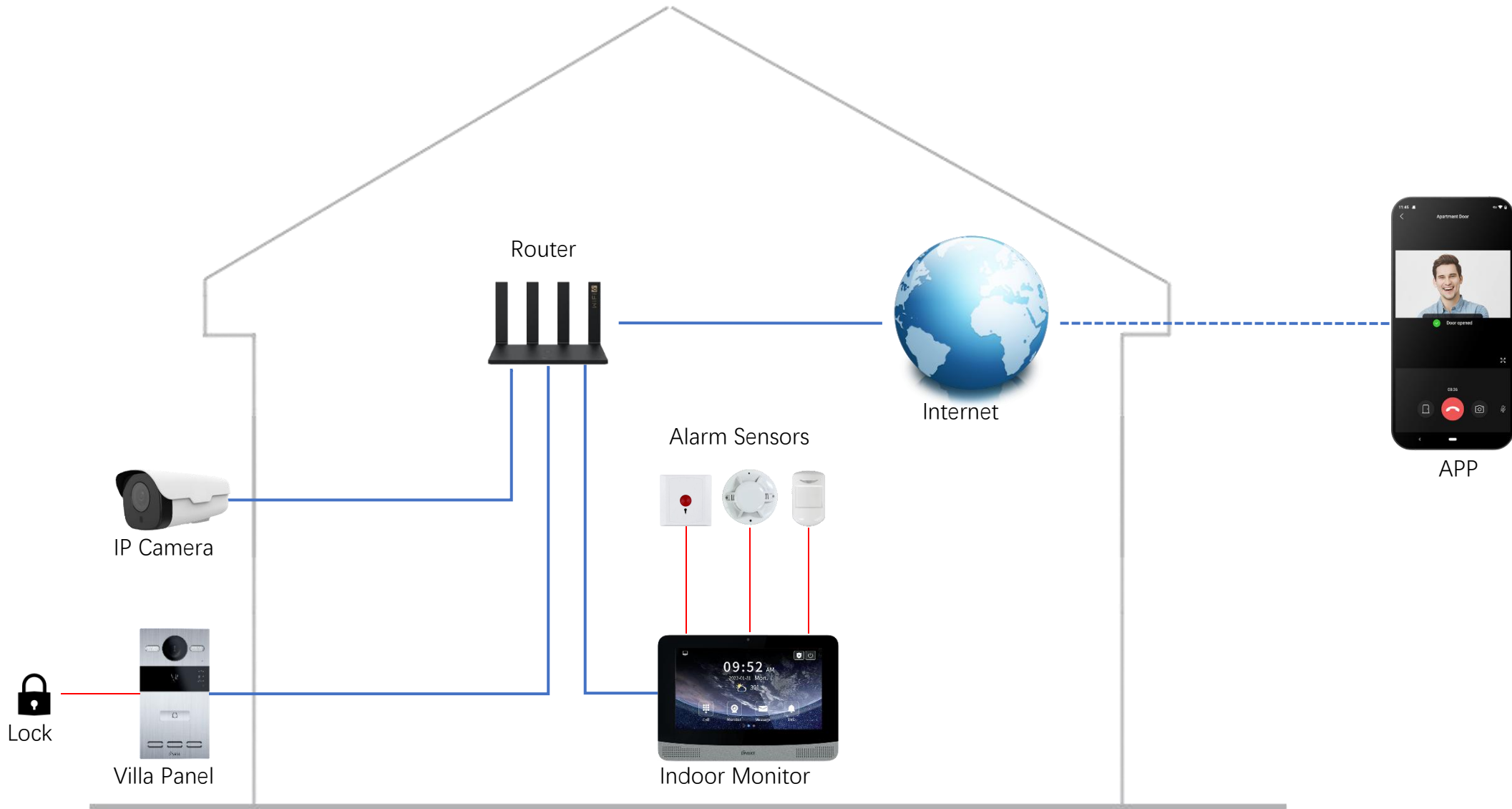

Residential Solution - Apartment

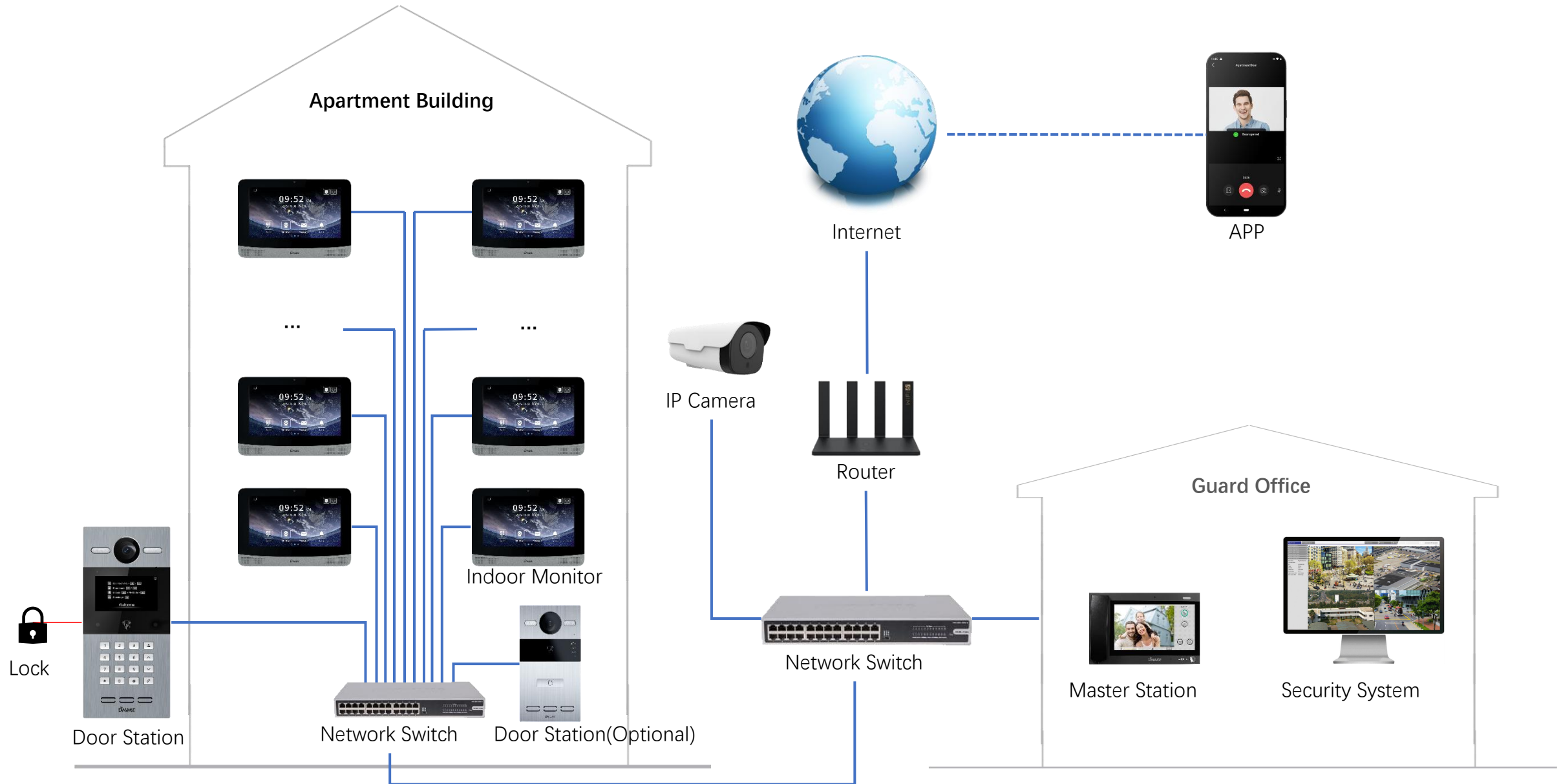

Residential Solution – Villa(2-Wire)

Capacity:
1 door station + 3 indoor monitors

Cat 5e ————

2 Wire ————

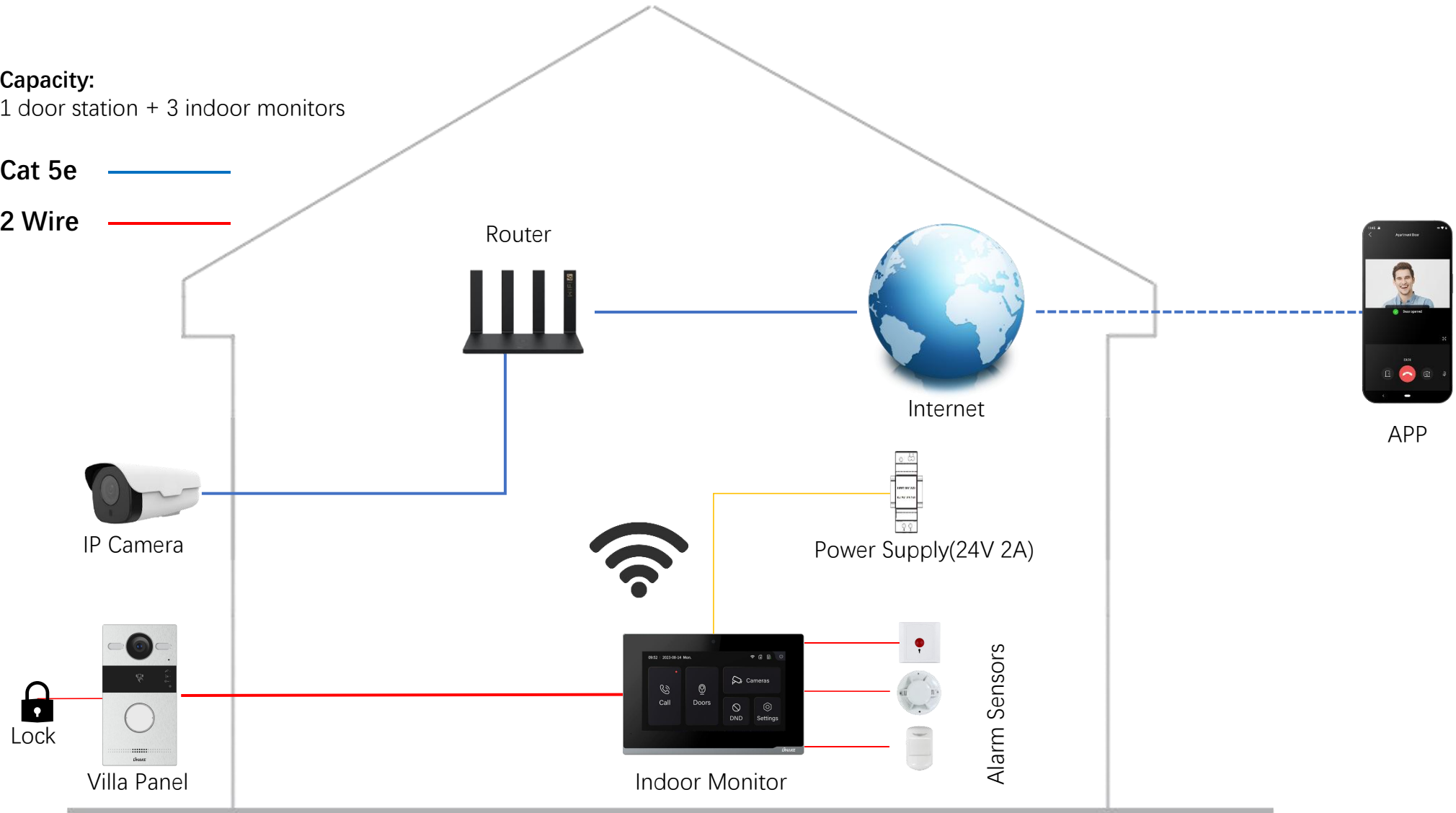

Residential Solution – Apartment(2-Wire)

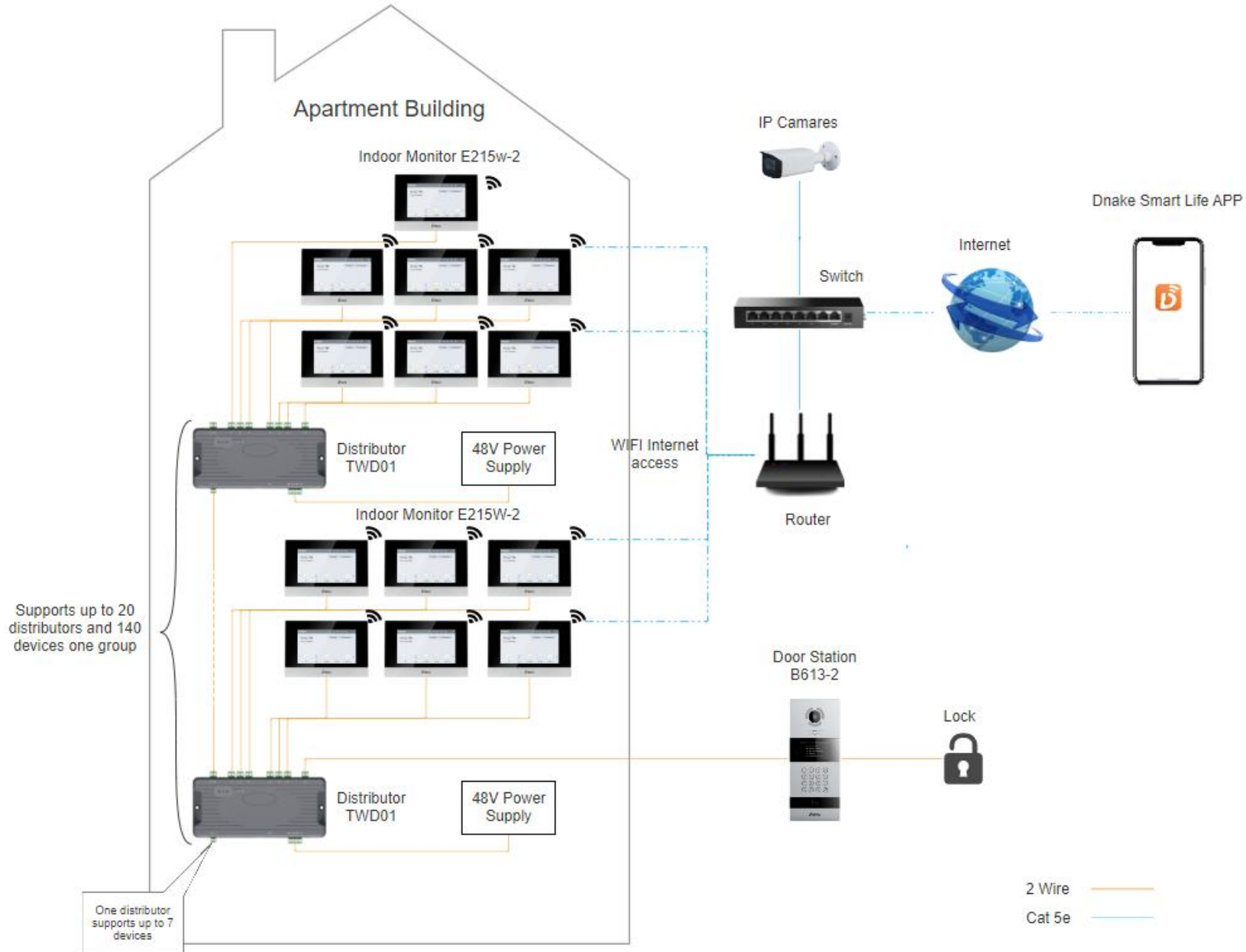

Residential Solution – Apartment(2-Wire)

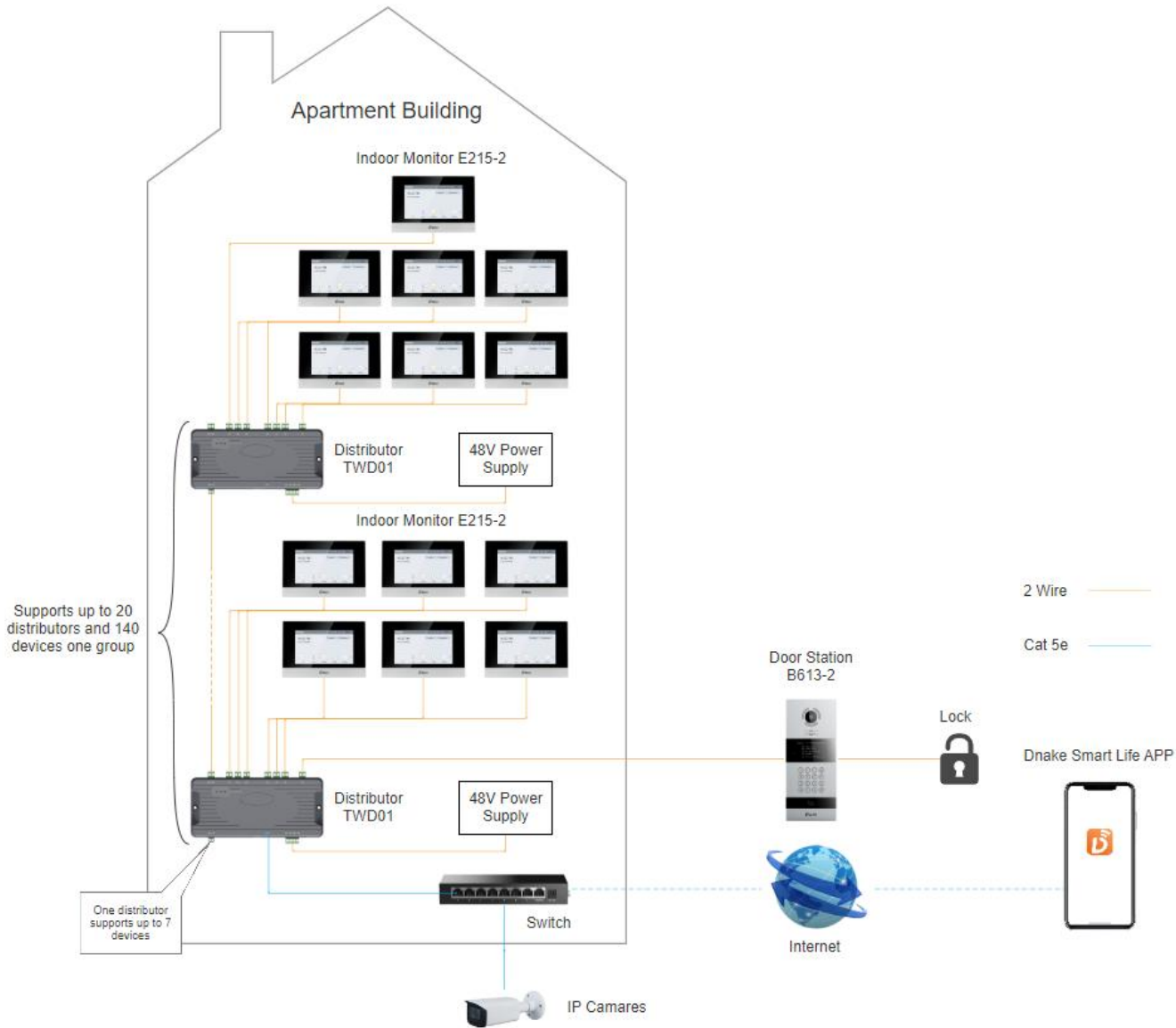

Residential Solution - Wireless Doorbell

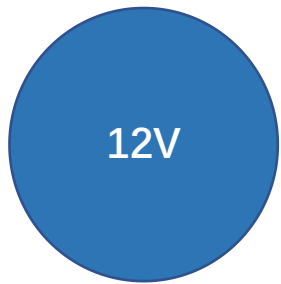
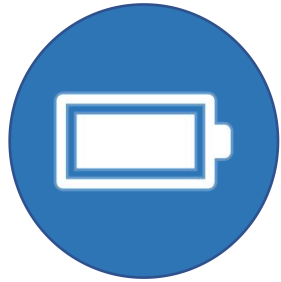

Commercial Solution – Office Building

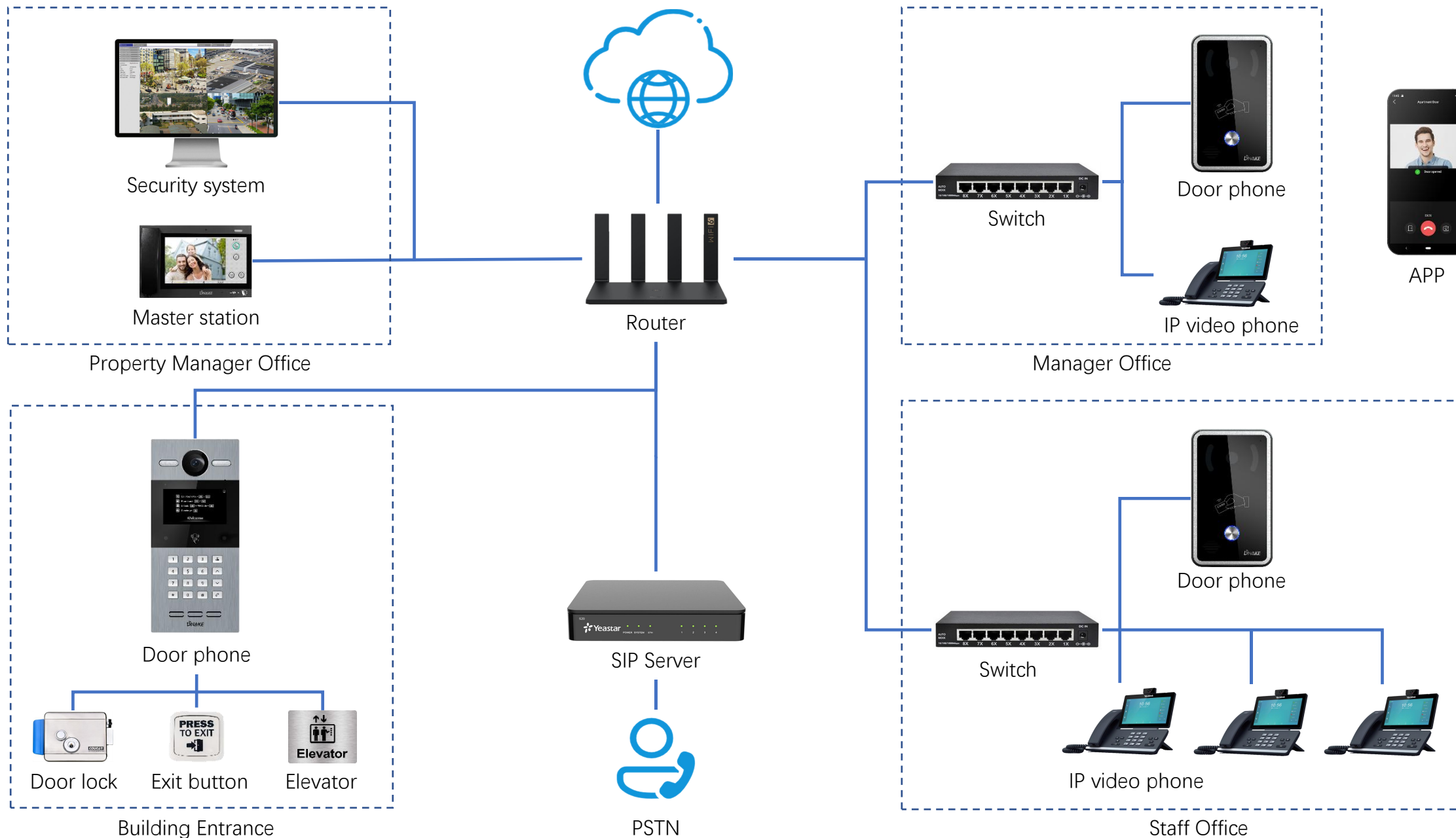

Smart Home Solution

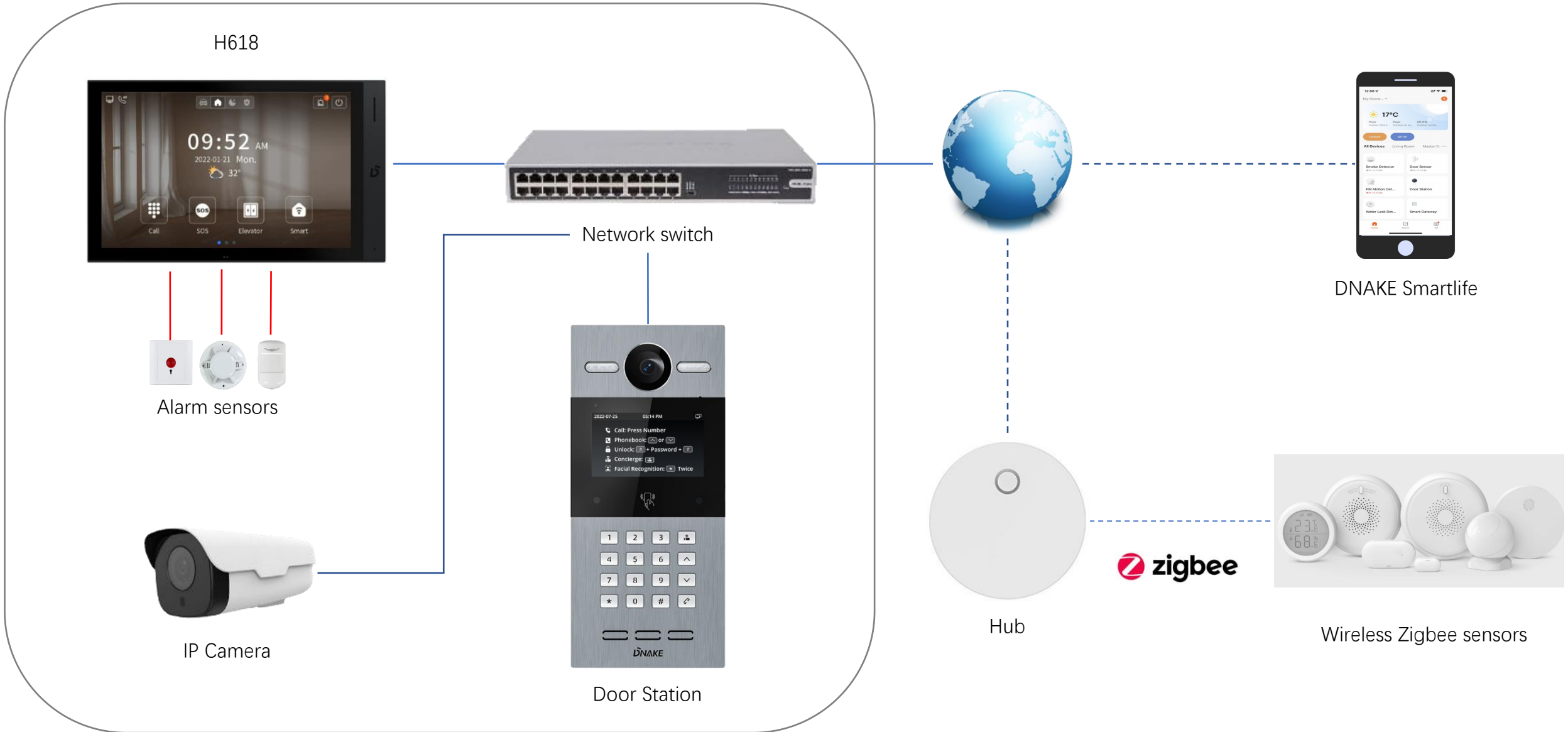

03

**DNAKE
PRODUCTS**

www.dnake-global.com



NEW



DNAKE S617

8" Facial Recognition Android Door Station

- Aluminum alloy panel
- 8" color IPS LCD
- 120° wide-angle 2MP HD camera, WDR
- Door entry methods: Face, Call, IC card (13.56MHz), ID card(125kHz), PIN code, APP, Bluetooth(optional)
- IP65, IK08
- Tamper alarm
- Standard PoE+ (IEEE802.3at) / 12V DC
- Anti-spoofing algorithm against photos and videos
- Support 20,000 faces, and 60,000 cards
- Low temperature resistance(-40°C to 55°C)
- Support surface & flush mount
- Easy integration with other SIP devices by SIP 2.0 protocol





DNAKE S615

4.3" Facial Recognition Android Door Station

- Aluminum alloy panel
- 4.3" color TFT LCD
- 120° wide-angle 2MP HD camera with automatic lighting
- Door entry methods: Face, Call, IC card (13.56MHz), ID card(125kHz), PIN code, APP
- IP65, IK08
- Tamper alarm
- Standard PoE (IEEE802.3af) / 12V DC
- Anti-spoofing algorithm against photos and videos
- Support 20,000 faces, and 60,000 cards
- Low temperature resistance(-40°C to 55°C)
- Support surface & flush mount
- Easy integration with other SIP devices by SIP 2.0 protocol



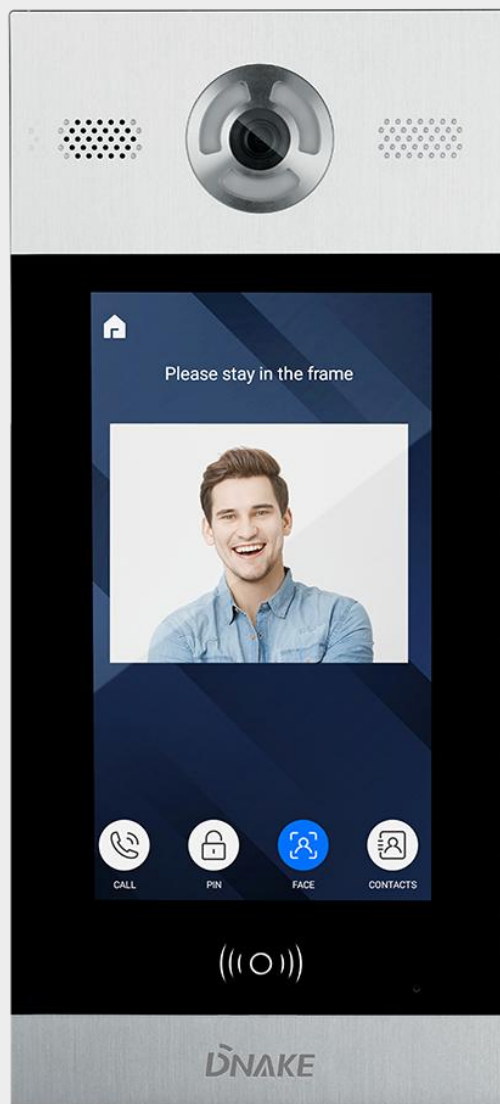

DNAKE 902D-B6

10.1" Facial Recognition Android Doorphone

- Aluminum alloy panel
- 10.1" capacitive touch screen
- 2MP HD camera with IR support
- Door entry methods: Call, Face, IC card(13.56MHz), PIN code, APP
- IP65 Water-proof & Dust-proof
- Standard PoE (IEEE802.3af) / 12V DC
- Anti-spoofing algorithm against photos and videos
- Support 10,000 faces, and 100,000 cards
- Low temperature resistance(-20°C to 55°C)
- Easy integration with other SIP devices by SIP 2.0 protocol





DNAKE S215

4.3" SIP Video Door Station

- Aluminum alloy panel
- 4.3" color TFT LCD
- 110° wide-angle 2MP HD camera with automatic lighting
- Door entry methods: Call, IC card (13.56MHz), ID card(125kHz), PIN code, APP
- IP65, IK08
- Tamper alarm
- Standard PoE (IEEE802.3af) / 12V DC
- Low temperature resistance(-40°C to 55°C)
- Support surface & flush mount
- Easy integration with other SIP devices by SIP 2.0 protocol



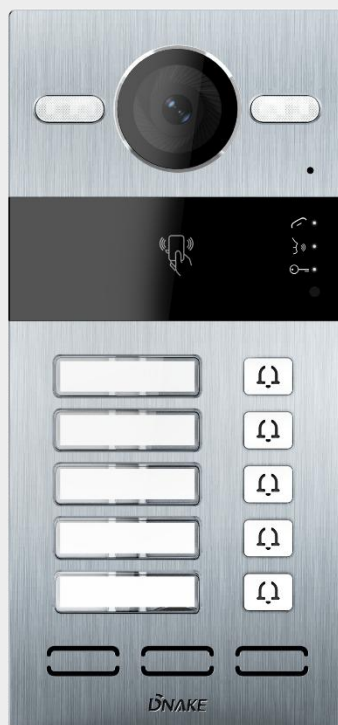

DNAKE S213M

Multi-button SIP Video Door Phone

- Aluminum alloy panel
- 110° wide-angle 2MP HD camera with automatic lighting
- Door entry methods: Call, IC card (13.56MHz), ID card(125kHz), APP
- 3 integrated indicators
- IP65, IK08
- Tamper alarm
- Standard PoE (IEEE802.3af) / 12V DC
- Low temperature resistance(-40°C to 55°C)
- Support surface & flush mount
- Easy integration with other SIP devices by SIP 2.0 protocol





DNAKE S213K

1-button SIP Video Door Phone with keypad

- Aluminum alloy panel
- 110° wide-angle 2MP HD camera with automatic lighting
- Door entry methods: Call, IC card (13.56MHz), ID card(125kHz), PIN code, APP
- 3 integrated indicators
- IP65, IK08
- Tamper alarm
- Standard PoE (IEEE802.3af) / 12V DC
- Low temperature resistance(-40°C to 55°C)
- Support surface & flush mount
- Easy integration with other SIP devices by SIP 2.0 protocol





DNAKE S212

1-button SIP Video Door Phone

- Aluminum alloy panel
- 110° wide-angle 2MP HD camera with automatic lighting
- Door entry methods: Call, IC card (13.56MHz), ID card(125kHz), APP
- 3 integrated indicators
- IP65, IK08
- Tamper alarm
- Standard PoE (IEEE802.3af) / 12V DC
- Low temperature resistance(-40°C to 55°C)
- Support surface & flush mount
- Easy integration with other SIP devices by SIP 2.0 protocol





DNAKE 280SD-C12

1-button SIP Video Door Phone

- Aluminum alloy panel
- 2MP HD camera with automatic lighting
- Door entry methods: Call, IC card (13.56MHz), APP
- Name tag
- IP65, IK07
- Standard PoE (IEEE802.3af) / 12V DC
- Low temperature resistance(-40°C to 55°C)
- Easy integration with other SIP devices by SIP 2.0 protocol





DNAKE C112

1-button SIP Video Door Phone

- Premium audio and video quality
- 2MP HD camera with automatic lighting, WDR
- Door entry methods: Call, IC card (13.56MHz), APP
- IP65 Water-proof & Dust-proof
- Standard PoE (IEEE802.3af) / 12V DC
- Motion Detection
- TF card, WIFI optional
- Low temperature resistance(-40°C to 55°C)
- Easy integration with other SIP devices by SIP 2.0 protocol





DNAKE 280SD-R5

Compact SIP Video Door Phone

- Premium audio and video quality
- 2MP HD camera with automatic lighting
- Door entry methods: Call, IC card (13.56MHz), APP
- Low temperature resistance(-40°C to 55°C)
- Easy integration with other SIP devices by SIP 2.0 protocol
- Ideal for environments with limited space





DNAKE H618

10" Android 10 Indoor Monitor

- HD quality audio and video communication
- 10" IPS capacitive touch screen, 1280 x 800
- Excellent performance with Android 10 OS
- 2GB RAM, 8 GB ROM
- Aluminum front panel
- Standard PoE (IEEE802.3af) / 12V DC
- 802.11b/g/n Wi-Fi and 2MP camera optional
- Support surface & desktop mount
- Easy integration with other SIP devices by SIP 2.0 protocol
- Easy integration with other smart home devices through 3rd-party apps





DNAKE 904M-S3

10.1" Android Indoor Monitor

- HD quality audio and video communication
- 10.1" capacitive touch screen, 1024 x 600
- User friendly interface, easy to use
- Video monitoring of DNAKE IP intercoms & IPC
- 8-ch alarm input, 1 x RS485
- Standard PoE (IEEE802.3af) / 12V DC
- 802.11b/g/n Wi-Fi optional
- Easy integration with other SIP devices by SIP 2.0 protocol
- Easy integration with other smart home devices through 3rd-party apps





DNAKE A416

7" Android 10 Indoor Monitor

- HD quality audio and video communication
- 7" IPS capacitive touch screen, 1024 x 600
- Excellent performance with Android 10 OS
- User friendly interface, easy to use
- Video monitoring of DNAKE IP intercoms & IPC
- 8-ch alarm input, 1 x RS485
- Standard PoE (IEEE802.3af) / 12V DC
- 802.11b/g/n Wi-Fi and 2MP camera optional
- Support surface & desktop mount
- Easy integration with other SIP devices by SIP 2.0 protocol
- Easy integration with other smart home devices through 3rd-party apps



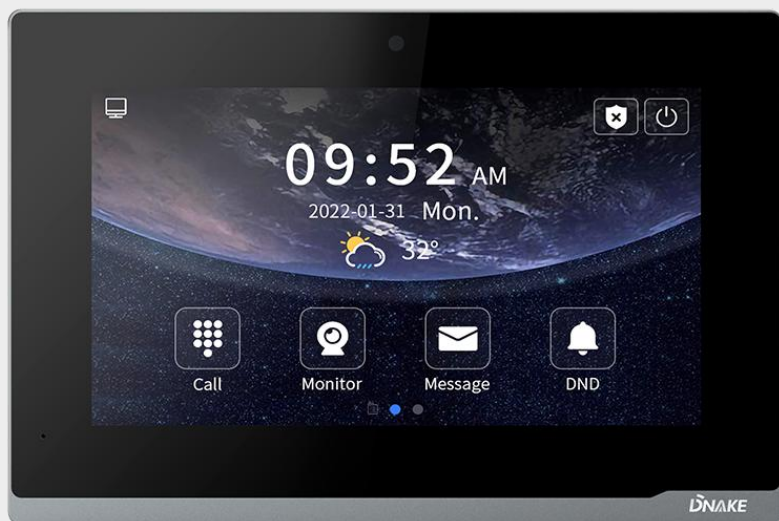

DNAKE E416

7" Android 10 Indoor Monitor

- HD quality audio and video communication
- 7" capacitive touch screen, 1024 x 600
- Excellent performance with Android 10 OS
- User friendly interface, easy to use
- Video monitoring of DNAKE IP intercoms & IPC
- 8-ch alarm input, 1 x RS485
- Standard PoE (IEEE802.3af) / 12V DC
- 802.11b/g/n Wi-Fi optional
- Support surface & desktop mount
- Easy integration with other SIP devices by SIP 2.0 protocol
- Easy integration with other smart home devices through 3rd-party apps



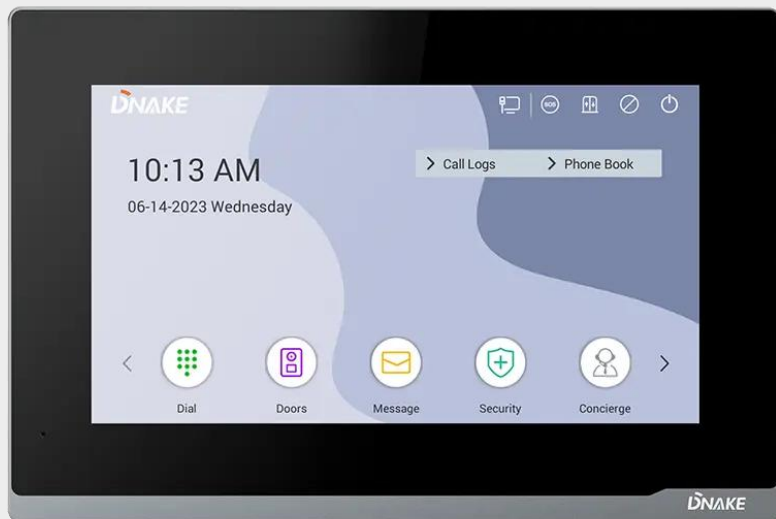

DNAKE E217

7" Linux-based WIFI Indoor Monitor

- HD quality audio and video communication
- 7" capacitive touch screen, 1024 x 600
- User friendly interface, easy to use
- Video monitoring of DNAKE IP intercoms & IPC
- 8-ch alarm input, 1 x RS485
- Standard PoE (IEEE802.3af) / 12V DC
- WIFI & TF card
- Support surface & desktop mount
- Easy integration with other SIP devices by SIP 2.0 protocol



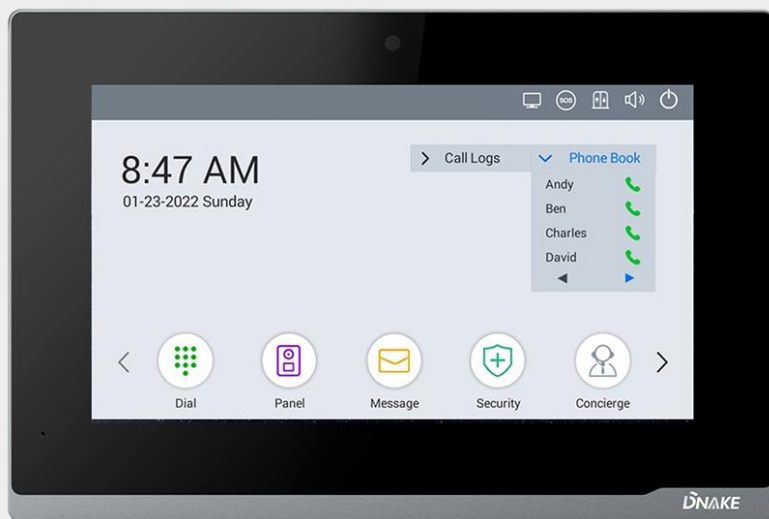

DNAKE E216

7" Linux-based Indoor Monitor

- HD quality audio and video communication
- 7" capacitive touch screen, 1024 x 600
- User friendly interface, easy to use
- Video monitoring of DNAKE IP intercoms & IPC
- 8-ch alarm input, 1 x RS485
- Standard PoE (IEEE802.3af) / 12V DC
- Support surface & desktop mount
- Easy integration with other SIP devices by SIP 2.0 protocol



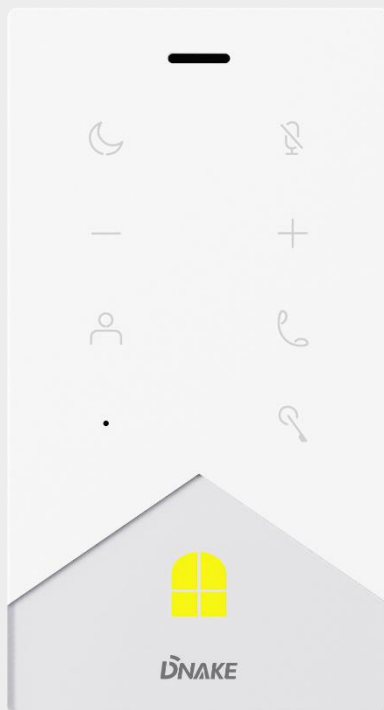

DNAKE E211

SIP Audio Indoor Monitor

- Stylish design with user-friendly LED indicator
- Fade-resistant keys
- High quality audio communication
- 8-ch alarm input, 1 x RS485
- Optional handset
- Optional Wi-Fi
- Powered by PoE or power adapter (DC12V/2A)





DNAKE 902C-A

Android-based IP Master Station

- Premium audio and video quality
- 10.1" capacitive touch screen, 1024 x 600
- Support two audio output modes: handsfree and handset
- Standard PoE (IEEE802.3af) / 12V DC
- Receive calls from devices
- Message Sending / Receiving
- Alarm / Call logs
- Remote unlocking
- Support monitoring 8 IP cameras
- Support 3rd-party apps





DNAKE IPK01

IP Intercom Kit

- Plug & Play
- User friendly interface
- Standard PoE
- One-touch calling
- Remote unlocking
- CCTV integration



DNAKE IPK02

IP Intercom Kit

- Plug & Play
- User friendly interface
- Standard PoE
- One-touch calling
- Remote unlocking
- CCTV integration



DNAKE IPK03

IP Intercom Kit

- Plug & Play
- User friendly interface
- Standard PoE
- One-touch calling
- Remote unlocking
- CCTV integration

NEW



DNAKE TWK01

2-wire Intercom Kit

- Plug & Play
- Quick Start Wizard
- Wi-Fi connection
- One-touch calling
- Remote unlocking
- CCTV integration
- 1 door station supports up to 3 indoor monitors

NEW



DNAKE B613-2

2-wire Apartment Door Station

- Front panel: Silver Aluminum alloy
- Display: 4.3 Inch, color TFT LCD
- Camera: 2 Mega pixels, automatic lighting, 80°(H) / 43°(V)
- Support Wiegand,13.56MHZ Card reader
- Output Relay: 2 output relay for door opener
- IP Rating: IP54
- Installation: Flush Mount
- Complies with SIP standard for easy integration in every SIP PBX

NEW



DNAKE E215-2/E215W-2

2-wire Indoor Monitor

- Easy configuration
- 7-inch capacitive touch screen
- Powered by 2-wire
- Support SIP 2.0 protocol, easy integration with other SIP devices
- Easy integration with elevator control system
- Support monitoring 8 IP cameras
- Optional Wi-Fi

NEW

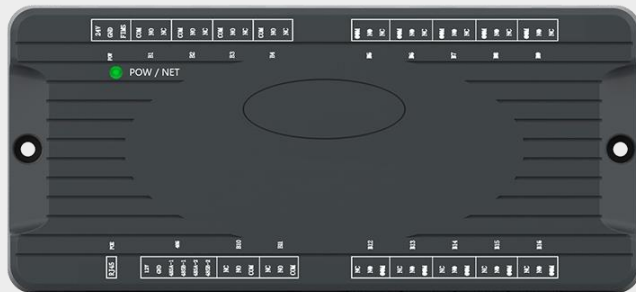

DNAKE TWD01

2-wire IP distributor

- Convert 2-wire to ethernet connection
- Two Ethernet Ports
- Support up to 7 devices(door station and indoor monitor), the total power cannot exceed 90 watts

DNAKE DK250

Wireless Doorbell

- 400m transmission distance in open area
- Easy Wireless Installation(2.4GHz)

DC200:

- IP65 Waterproof
- Tamper Alarm
- Working temperature: -10°C - +55°C
- One door camera support two indoor monitors
- Dual power options: Battery or DC 12V

DM50:

- 7" TFT LCD, 800 x 480
- Real-time Monitoring
- One-key Unlock
- Photo Capture & Video Record (TF card, MAX:32G)
- Rechargeable Lithium Battery (2500mAh) or DC 12V
- Desktop / Surface Mounting



DNAKE DK230

Wireless Doorbell

- 400m transmission distance in open area
- Easy Wireless Installation(2.4GHz)

DC200:

- IP65 Waterproof
- Tamper Alarm
- Working temperature: -10°C - +55°C
- One door camera support two indoor monitors
- Dual power options: Battery or DC 12V

DM30:

- 2.4" TFT LCD, 320 x 240
- Real-time Monitoring
- One-key Unlock
- Photo Capture
- Rechargeable Lithium Battery (1100mAh) or DC 12V
- Desktop mounting



DC200



DM30

DK230

NEW



DNAKE H618

Smart Control Panel

- 10" IPS capacitive touch screen, 1280 x 800
- Front panel: Aluminum
- RAM: 2GB, ROM: 8GB
- Two-way communication based on SIP v2.0 protocol
- Powered by PoE or external source
- Zigbee Hub and sensor integration

NEW



DNAKE MIR-MC100-TY

Door and Window Sensor

- Communication: Zigbee 3.0
- Working Voltage: DC 3V (CR2032 battery)
- Low battery indication
- Battery Life: 1 year (20 times per day)
- Working Temperature: -10°C to $+55^{\circ}\text{C}$
- Trigger Distance: 23 ± 5 mm
- Dimension: Main body: $52.6 \times 26.5 \times 13.8$ mm,
Magnet: $25.5 \times 12.5 \times 13$ mm

NEW



DNAKE MIR-SM100-TY

Smoke Sensor

- Communication: Zigbee 3.0
- Working Voltage: DC 3V (CR2032 battery)
- Low battery indication
- Battery Life: 3 years (20 times per day)
- Working Temperature: -10°C to +55°C
- Alarm Sound Pressure: ≥ 80 dB (3 m in front of the smoke sensor)
- Dimension: $\Phi 90 \times 37$ mm

NEW



DNAKE JT-GA100-ZB

Gas Sensor

- Communication: Zigbee 3.0
- Working Voltage: AC 220V
- Standby Current: ≤ 200 mA
- Detected Gas: Methane (natural gas)
- Alarm LEL: 8% LEL Methane (Natural gas)
- Detection error rate: ± 3 % LEL
- Working Temperature & Humidity: -10°C to $+55^{\circ}\text{C}$, $\leq 95\%RH$
- Alarm sound pressure: ≥ 70 dB (1 m in front of the gas sensor)
- Dimension: $\Phi 85 \times 30$ mm

NEW



DNAKE MIR-WA100-TY

Water Leak Sensor

- Communication: Zigbee 3.0
- Working Voltage: DC 3V (CR2032 battery)
- Low battery indication
- Battery Life: 1 year (20 times per day)
- Working Temperature: -10°C to +55°C
- Dimension: $\Phi 50 \times 18$ mm

NEW



DNAKE MIR-IR100-TY

Motion Sensor

- Communication: Zigbee 3.0
- Working Voltage: DC 3V (CR123A battery)
- Low battery indication
- Battery Life: 3 years
- Detection Distance: Up to 8 m
- Detection Angle: 90°
- Installation Height: 2.2 m
- Dimension: 48.4 x 53.4 mm

NEW



DNAKE MIR-TE100

Temperature and Humidity Sensor

- Communication: Zigbee 3.0
- Working Voltage: DC 3V (2x alkaline battery 1.5V LR03 / AAA)
- Low battery indication
- Battery Life: 3 years
- Working Temperature & Humidity: -10°C to +55°C, 0% to 99.9%RH
- Dimension: Φ 61.2 x 23 mm

NEW



DNAKE MIR-SO100-TY

Smart Button

- Communication: Zigbee 3.0
- Working Voltage: DC 3V (CR2032 battery)
- Low battery indication
- Battery Life: 1 year (20 times per day)
- Working Temperature: -10°C to +55°C
- Dimension: $\Phi 50 \times 16$ mm

NEW



DNAKE MIR-GW200-TY

Smart Hub

- Communication: Zigbee 3.0, Bluetooth Sig Mesh, Wi-Fi 2.4GHz
- Zigbee communication distance: ≤ 100 m (Open area)
- Support up to 32 sub-devices
- Power Supply: Micro USB DC5V
- Working Voltage: 1.8V ~ 3.3V
- Working Current: < 1 A
- Working temperature: -10°C to $+55^{\circ}\text{C}$
- Working Humidity: 10% - 90% RH (Non-condensing)
- Dimension: 60 x 60 x 15 m



DNAKE Cloud Service

Cloud-Based Video Intercom Service

- Cloud calling
- Remote management
- All-in-one centralized management
- Batch device management
- Role-based access control management
- Security:
 - Hosting: The DNAKE cloud platform is hosted on Amazon Web Services (AWS);
 - International standards: GDPR compliant;
 - Encryption: SIP/TLS, SRTP and ZRTP, secure user authentication, end-to-end encryption, post quantum encryption.













DNAKE Smart Pro APP

Cloud-based Intercom App









- Video preview before call pick-up
- Video calls on you mobile phone
- Remote door unlocking
- QR code & Bluetooth unlocking
- Temporary key for visitors
- Video monitoring of door station
- Incoming call push notification
- Security alarm push notification
- Door release logs



Selection Guide

Application	Apartment/Office					Apartment/Villa/Office	Villa/Office			
Positioning	Premium		Mid-range			-	Premium	Mid-range	Entry Level	
Model	S617	S615	902D-B6	S215	S213M	S213K	S212	280SD-C12	C112	280SD-R5
Image										
Display	8" IPS	4.3" TFT	10.1" TFT	4.3" TFT	×	×	×	×	×	×
Touch Screen	✓	×	✓	×	×	×	×	×	×	×
Front Panel	Aluminum	Aluminum	Aluminum	Aluminum	Aluminum	Aluminum	Aluminum	Aluminum	ABS	ABS
Operating System	Android	Android	Android	Linux	Linux	Linux	Linux	Linux	Linux	Linux
PoE	✓ (PoE+)	✓	✓	✓	✓	✓	✓	✓	✓	×
SIP	✓	✓	✓	✓	✓	✓	✓	✓	✓	✓
ONVIF	✓	✓	×	✓	✓	✓	✓	✓	×	✓
Camera	✓	✓	✓	✓	✓	✓	✓	✓	✓	✓
PIN / Card Entry	✓	✓	✓	✓	✓	✓	✓	✓	✓	✓
Biometric Access	✓	✓	✓	×	×	×	×	×	×	×
IP/IK Rating	IP65/IK08	IP65/IK08	IP65	IP65/IK08	IP65/IK08	IP65/IK08	IP65/IK08	IP65/IK07	IP65	For indoor
Wiegand	✓	✓	✓	✓	✓	✓	✓	×	✓	×
Relay out	3	3	1	3	2	2	2	1	1	1
RS485	✓	✓	✓	✓	✓	✓	✓	✓	✓	✓
WIFI	×	×	×	×	×	×	×	×	Optional	×
TF card Slot	×	×	×	×	×	×	×	×	✓	×
Installation	Flush or Surface	Flush or Surface	Flush	Flush or Surface	Flush or Surface	Flush or Surface	Flush or Surface	Flush or Surface	Surface	Surface

Selection Guide

Application	Living room/Bed room/Kitchen/Office/etc.							Guard room
Positioning	Premium		Mid-range		Entry Level			-
Model	H618	A416	904M-S3	E416	E217	E216	E211	902C-A
Image								
Display	10.1" IPS 1280*800	7" IPS 1024*600	10.1" TFT 1024*600	7" TFT 1024*600	7" TFT 1024*600	7" TFT 1024*600	×	10.1" TFT 1024*600
Touch Screen	✓	✓	✓	✓	✓	✓	Touch key	✓
Front Panel	Aluminum	ABS	ABS	ABS	ABS	ABS	ABS	ABS
RAM	2GB	1GB	1GB	1GB	128MB	64MB	64MB/128MB	512MB
ROM	8GB	8GB	4GB	8GB	128MB	128MB	16MB	4GB
Operating System	Android 10	Android 10	Android 6	Android 10	Linux	Linux	Linux	Android
PoE	✓	✓	✓	✓	✓	✓	✓	✓
SIP	✓	✓	✓	✓	✓	✓	✓	✓
Camera	Optional	Optional	Optional	×	×	×	×	✓
Wi-Fi	Optional	Optional	Optional	Optional	✓	×	Optional	×
Handset	×	×	×	×	×	×	Optional	✓
3rd-party Apps	✓	✓	✓	✓	×	×	×	✓
Smart Sensor Control	✓	×	×	×	×	×	×	×
Installation	Surface or Desktop	Surface or Desktop	Surface	Surface or Desktop	Surface or Desktop	Surface or Desktop	Surface	Desktop



EASY & SMART INTERCOM SOLUTIONS



86-592-5705812



www.dnake-global.com



sales01@dnake.com