



for a safer world!

BS-377/WP/A Autonomous waterproof liquid gas-LPG detector with relay
BS-378/WP/A Autonomous waterproof natural gas-methane detector with relay



II 3G Ex ec IIA T6 Gc

TECHNICAL CHARACTERISTICS

| | |
|--|---|
| OPERATION VOLTAGE | 197-265V AC |
| MAXIMUM CONSUMPTION | 3VA (at 230V AC) |
| % L.E.L ALARM | Selectable at 10% and 20% L.E.L |
| SENSOR TYPE | catalytic |
| MEASUREMENT RANGE | 0-50 L.E.L. |
| SENSOR LIFE SPAN | 5 years (*) |
| SENSOR STABILIZATION PERIOD DURING STARTUP | 60 seconds |
| RESPONSE TIME (T ₉₀) | <45 seconds |
| REPEATABILITY | = ±1.5 L.E.L. |
| MAXIMUM DEVIATION (after calibration) | ≤ ±1.5 L.E.L. |
| CHANGE | ≤ ±4.5 L.E.L./year |
| INDICATORS | Operation LED (green) |
| | Fault LED (yellow) |
| | Alarm LED (red) |
| | Buzzer |
| OUTPUTS / CONNECTIVITY | Alarm relay (240VAC / 5A N.O. / 2A N.C.), latching/non-latching |
| | Fault relay (240VAC / 5A N.O.) |
| DEGREES OF COVER PROTECTION | IP65 |
| | PRODUCED IN ACCORDANCE WITH |
| OPERATION AND STORAGE CONDITIONS | -10 to 60 °C |
| | 10 to 95% relative humidity (with no condensation) |
| CONSTRUCTION MATERIAL | 1 atm ±10% |
| EXTERNAL DIMENSIONS | ABS/PC, PC |
| TYPICAL WEIGHT | 145 x 85 x 45 mm |
| GUARANTEE | 300gr. |
| | 2 years (**) |

(*) = (Ideal conditions) When the detector is exposed to **cleaning agents, silicones and generally in commercial and light industrial environments**, it is recommended to be calibrated every year and its sensor to be replaced every 3 years!
ATTENTION!! DO NOT USE LIQUID GAS (i.e. lighter gas) FOR SENSOR TESTING BECAUSE IT CAUSES PERMANENT DAMAGE. Use calibration gas up to 50% L.E.L. for this purpose.

(**) = does not cover the gas sensor, if it is exposed to Si, H2S, Pb & halogenated hydrocarbon.

Thank you for your trust in our products

Olympia Electronics - European manufacturer

GENERAL

The BS-377/WP/A and BS-378/WP/A explosive gas detectors are used to measure the concentrations in % L.E.L. (Lower Explosive Level) while simultaneously providing autonomous notification/alarm operations in case there is a leak of liquid on natural gas. They are used in commercial and small industrial areas such as professional kitchens and burner rooms.

The installation must be done by trained personnel that has previously read the instruction manual.

In case on an alarm or gas leak:

Keep calm and follow the instruction below independent of their order.

- Turn off all burning flames and anything that is smoking.
- Close all gas appliances (kitchens - burners - cookers etc.)
- Close the central gas supply or canister.
- Open doors and windows in order to ventilate the area.

Avoid :

- Turning on/off the wall switches or the detector.
- Using a mobile phone in the area that is

suspected to have the gas leak.
If the alarm continues then evacuate the building and inform the gas supply company.

Mounting

Depending on the gas type that we want to detect, the device should be mounted with the sensor pointed downward (maximum allowed deviation $\pm 20^\circ$), **20-30cm from the ceiling** (for methane, natural gas) or **20-30cm from the floor** (for propane, butane, liquid gas, LPG), up to 4 meters (in a horizontal distance) from probable leak points and away from air drafts and humidity.

The detectors must not be placed:

- Near ventilators or near doors and windows.
- In an external area.
- In an area that is located near:
 - Corrosives or solvents e.t.c.
 - Silicones (e.g. insulation, glues, detergents)
 - Sulfuric compounds
 - halogenated hydrocarbon.
 - Organic phosphoric compounds.

Installation

To mount the device, unfasten the 4 retaining screws.(figure 1). Next, using the diagram on figure 2 to realize the external connections of the system. The device operates with a mains voltage of 240V AC (with a voltage range of 197 to 265V AC).

ATTENTION!!!

To maintain the degree of IP65 the waterproofing gasket must be fitted to the top of the chassis of the device. Also after each opening of the chassis of the device the condition of the gasket should be checked and replaced if damage occurs.

Dip-switches settings

The BS-377/WP/A and BS-378/WP/A detectors (figure 3), have six dip-switches to adjust the operation mode.

Below you can see these mode settings and there meaning:

TABLE 1

| Dip-switch | Function | | |
|------------|---------------------------------------|-----|---|
| S1&S2 | Dip-switch combinations | | |
| | S1 | S2 | |
| | OFF | OFF | <i>Normal operation (default)</i> |
| | ON | OFF | Test for outputs (relay, led, buzzer) |
| | OFF | ON | Calibration with clean air |
| | ON | ON | Calibration with reference gas |
| S3 | ON | | Latching alarm relay and red led (default) |
| | OFF | | With no latching |
| S4 | ON | | Calibration reference gas concentration 50% L.E.L. (Default) |
| | OFF | | Calibration reference gas concentration 20% L.E.L. |
| S5 | ON | | Alarm function at 20% L.E.L. |
| | OFF | | Alarm function at 10% L.E.L. (default) |
| S6 | <i>Does not provide any operation</i> | | |

-S1 & S2. These switches determine the operation of special maintenance and test functions. To conduct these functions, select the suitable combination with the switches S1 and S2 and press the internal button BT2 (figure 3) for more than 1 second. The function «output test» activates all the LEDs, the buzzer and the alarm relay and deactivates the fault relay while the button is being pressed. For the calibration function, detailed instructions are given later on in this manual.

-S3. When the latching function is selected then when the detector senses a gas concentration equal to or greater than % L.E.L the alarm relay and the alarm led (red) remain activated even if the concentration of % L.E.L. returns to normal levels. The deactivate them, the external button LAY 5-BP111 can be used.

-S4. This operation refers to the special operation calibration function with reference gas. Via S4 select the concentration of gas that will be used (20% or 50% L.E.L.)

-S5. This setting refers to the concentration in % L.E.L. that must be detected in order to activate the alarm relay, the red led and the buzzer. 10% or 20% L.E.L. can be selected. After the selection is made, the concentration of gas that is considered to be normal is below 2.5% L.E.L. from the selected setting, that is below 7.5% or 17.5% L.E.L. respectively.

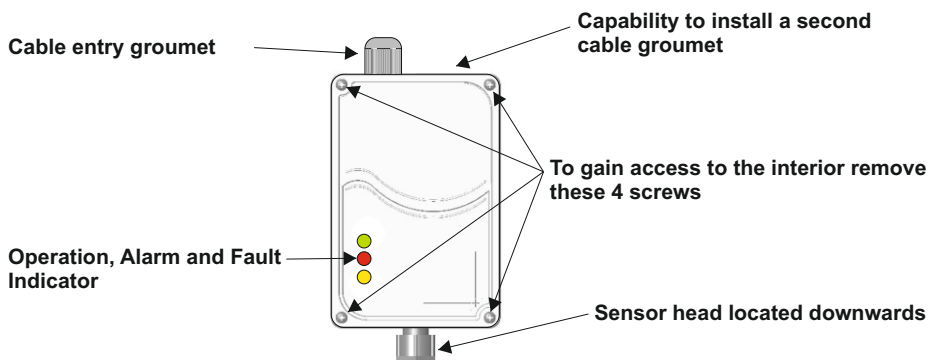

Figure 1. Interior access, cable entry and indicators

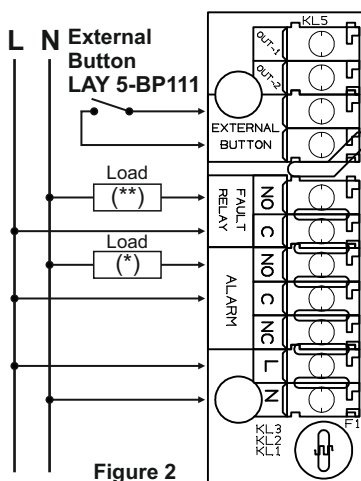

Figure 2

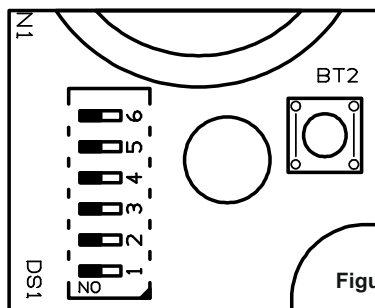

Figure 3

(*) Electro-valve / beacon / siren / power relay.
 (**) Electro-valve / beacon / siren / power relay.
 Warning!!! The contact is closed during normal operation and open during a fault.

Alarm relay

The alarm relay is activated when the concentration % L.E.L. of the sensed area exceeds the alarm level (10% or 20%). The relay returns to normal operation when the gas concentration returns to normal levels. If the latch function has been selected via the S3 switch, then the relay remains activated even if the gas levels return to normal. In this case, to deactivate it, use the external button LAY 5-BP111 that must be pressed for more than 2 seconds.

Fault Relay

The fault relay has one contact that is closed (N.C.) when the system is powered and there are no malfunctions. This contact opens when there is no power or there is a malfunction

Buzzer

The buzzer is activated (beeps every second) when the concentration of % L.E.L. in the covered area exceed the alarm selected level (10% or 20%). The buzzer stop automatically when the gas concentration returns to normal levels. While the buzzer is activated it can be silenced using the external button LAY 5-BP111 which must be pressed for more than 2 seconds.

The buzzer is also activated in case of a system malfunction (5 short beeps with 10 second pauses in between).

Incase of a simultaneous alarm and error event, priority is given to the indication of the alarm event.

Green LED (operation indicator)

The green LED indicates the presence of the power supply and special operation states as described in table 2.

Red LED (alarm indicator)

The red LED is activated when the gas concentration of % L.E.L. in the covered area exceeds the selected alarm level (10% or 20%). The LED is deactivated when the gas concentration returns to normal levels. If the latching function has been selected via the S3 micro switch then the LED remains active (blinks every second) even if the gas concentration drops to a safe level. To deactivate it, use the external button LAY 5-BP111 that must be pressed for more than 2 seconds.

Yellow LED (Fault indicator)

The yellow LED indicates a system malfunction or fault and also some special states as shown in table 3 (page 4).

TABLE 2

| Green LED Operation | Explanation |
|---|---|
| Permanently activated | The system is powered |
| Intermittent operation every second | The system is in the initialize pre-heat phase of the sensor. This phase last for 60 seconds |
| Intermittent brief illumination once a minute | The supply of the system is out of limits |

TABLE 3

| Yellow LED Operation | Explanation |
|---|---|
| Permanently activated | Probable cause: -The power supply of the system is out of operation limits (in combination with the green led operation). Check the power supply of the system. -gas sensor malfunction. Replace sensor. -Central processor malfunction. Service required. |
| Intermittent operation every second | Problem with the system settings. Repeat the clear air and reference gas calibration procedure. |
| Intermittent brief illumination once a minute | The current concentration of gas has exceeded the high detection limit of the device that is 50% L.E.L. Normal operation is restored automatically when the gas concentration drops to within the measuring limits of the unit. |

Input for external button LAY 5-BP111

The external button LAY 5-BP111 operates in surrounding temperature: $-25\sim+55^{\circ}\text{C}$, the rated insulation voltage is: 600V AC (50-60Hz) and the IP rating is: IP40 . The external button can be used to mute/reset the alarm relay, Buzzer and Red indicator as described in each section.

WARNING!!! The cable length between the external button and the system must not exceed three (3) meters.

System Calibration

WARNING!!! The calibration procedure of the detector must be done by qualified personnel that have previously read the user manual.

-The special calibration function is not available to the user if there are faults in the system.

-For the calibration procedure using a reference gas, the OL-11 calibration kit is required. (figure 4).

-For the calibration procedure using a reference gas, a mixture **20% or 50% L.E.L. with oxygen and nitrogen is used**. The explosive gas catalytic sensors do not operate without oxygen.

-It is suggested to conduct the calibration test at least once every 12 months.

-During the calibration procedure, conduct a clean air calibration and then a reference gas calibration.

To calibrate the device, remove the 4 retaining screws (figure 1) in order to gain access to the interior.

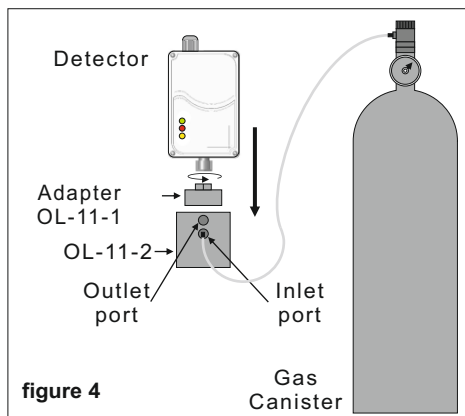

Clean air calibration

Take the following steps:

1.Ensure that the environment is clean and does not contain explosive gases.

2.Select using the switches S1 and S2 (figure 3) the special function «Clean air calibration»

3. Press the button BT2 (figure 3) for more than 3 seconds until the 3 system LEDs(green,red and yellow) start to blink with a one second rate.

4.Wait 4 seconds until the procedure is completed. **This step may last 60 seconds**

more in some instances.

When the procedure is finished, the yellow led and the buzzer operate intermittently. **(intermittent brief activation every second).**

At this point there are two instances:

-The green led is lit. This means that the clean air calibration has finished with success. Press and hold the button BT2 for more than 1 second to exit calibration mode and to return the detector to normal operation.

-The red led is lit. The clean air calibration procedure did not finish successfully. Press and hold the button BT2 for more than 1 second to exit calibration mode and to return to normal operation. You can repeat the process by following the steps from the beginning.

Calibration using a reference gas

The steps for calibrating using a reference gas are the following:

1. Ensure that the environment is clean and free from explosive gases.

2.Remove the gland with the filter located on the sensor head (figure 1).

3. In its position install the accessory OL-11-1 of the calibration kit OL-11 (figure 4).

4. Install the part OL-11-2 on the part OL-11-1 (figure 4).

5. Select via the micro-switch S4 (figure 3) the concentration of the reference calibration gas that will be used (20% or 50% L.E.L.).

6. Select via the micro-switches S1 and S2 (figure 3) the special operation «Calibration with a reference gas».

7. Press and hold the button BT2 (figure 3) for more than 3 seconds until the 3 system LEDs (green, red and yellow) start to blink **(intermittent blink once a second)** and then release the button.

8. Open the steady pressure valve (**0.3L / minute**) of the reference gas canister.

9. Wait 3 minutes until the procedure finishes. **This step may last 60 seconds more in some instances.**

While waiting for the procedure to complete you can cancel it at any time by pressing the Bt2 button for more than 3 seconds.

When the procedure is finished, the yellow led and the buzzer operate intermittently. **(intermittent brief activation every second).** **At this point close the flow valve on the gas canister.**

At this point there are two instances:

-The green led is lit. This means that the reference gas calibration procedure has finished with success. Press and hold the button BT2 for more than 1 second to exit calibration mode and to return the detector to normal operation.

-The red led is lit. The reference gas calibration procedure did not finish successfully. Press and hold the button BT2 for more than 1 second to

exit calibration mode and to return to normal operation. You can repeat the process by following the steps from the beginning. After the calibration procedure is finished and before normal operation remove the part OL-11-2, unscrew the part OL-11-1 and reinstall the gland with filter to the sensor head.

WARRANTY

Olympia Electronics guarantees the quality, condition and operation of the goods. The period of warranty is specified in the official catalogue of Olympia Electronics and also in the technical leaflet, which accompanies each product. This warranty ceases to exist if the buyer does not follow the technical instructions included in official documents given by Olympia Electronics or if the buyer modifies the goods provided or has any repairs or re-setting done by a third party, unless Olympia Electronics has fully agreed to them in writing. Products that have been damaged can be returned to the premises of our company for repair or replacement, as long as the warranty period is valid.

Olympia Electronics reserves the right to repair or to replace the returned goods and to or not charge the buyer depending on the reason of defection. Olympia Electronics reserves the right to charge or not the buyer the transportation cost.

HEAD OFFICE

72nd km. O.N.R. Thessaloniki-Katerini
P.C. 60300 P.O. Box 06 Eginio Pierias Greece

www.olympia-electronics.gr
info@olympia-electronics.gr